



BAK

Evaporator family

THE BAK A NEW GENERATION

TAKING THE BEST FROM
THE PAST, EXPANDING YOUR
HORIZONS FOR THE FUTURE!

The BAV 2000 - a production giant



“MORE THAN 2000
BAK SYSTEMS
DELIVERED
WORLDWIDE”



Assisted calotte transfer - available across the BAK range

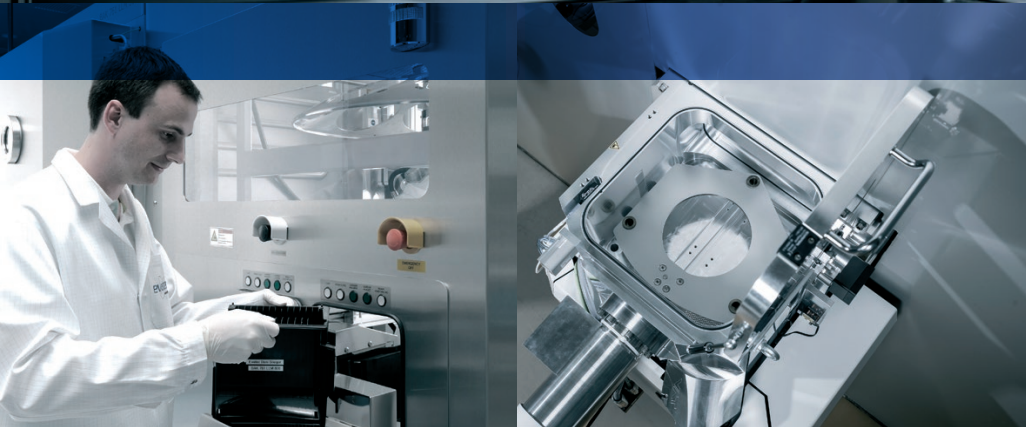

Complete calotte fill and transfer - from single wafer manual transfer on the BAK 501 all the way to fully automated cassette handling on the BAK 1101 with AUTOLOAD

Welcome to the new generation BAK evaporator - a whole family of platform sizes and geometries taking all the best from the tried and tested BAK generations before, and extending your capabilities with new sources, new process control options and new handling concepts.

THE BAK

JUST THE RIGHT SIZE



Substrate capacity by machine type (with calotte)

BAK	501	641	701	761	901	1101	1401	2000
2"	47	95	106	152	186	216	330	on request
3"	20	36	44	64	88	104	167	on request
4"	9	24	26	40	51	64	104	256
6"	5	9	10	18	23	24	47	114
8"	3*	6	7	9	10	16	28	65

The BAK batch coater delivers thin film deposition and etch capabilities for precision optics, optoelectronics and semiconductor applications to customers around the globe. From deposition of multilayer dielectrics and metals, to TCOs or whole range of compounds, it can be configured just the way you need for directional coating, enhanced thickness uniformities and the tightest optical, mechanical and environmental specifications.

Our applications specialists are here to help you identify just the right platform in our range between 0.5 metres and 2.0 metres according to your throughput and processes. The new generation BAK family brings you the complete solution including processes and substrate handling knowhow on a platform with proven production reliability for the best ever cost of ownership.

*with planets

“FOR THE
BEST COST OF
OWNERSHIP”

LEADING THE WAY WITH ADVANCED PROCESS CONTROL (APC)

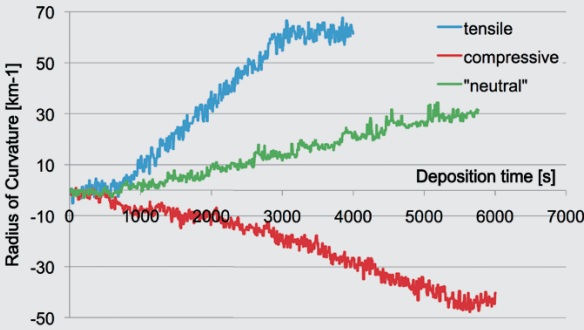

Mirror: Stress at various deposition conditions

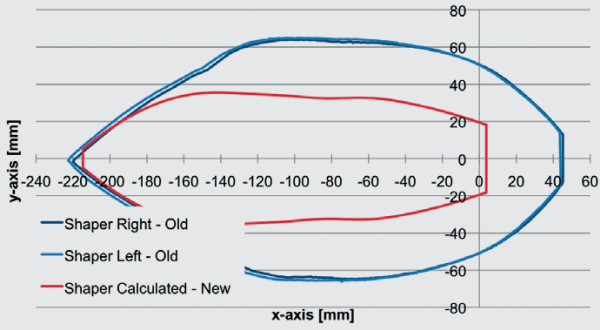

“Unicalc” fast track shaper development for reduced materials consumption

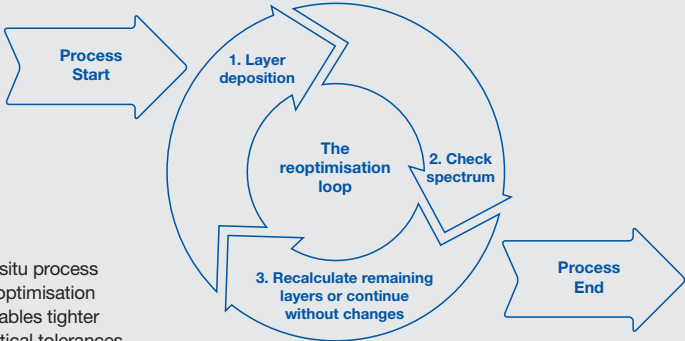

Full automation through pump down, process and vent and full data logging functionality on Evatec’s “KHAN” system and process controller make production and quality control easier than ever. Information is displayed according to SEMATECH standards and compliance to GEM, SECS-I and primary aspects of SECS-II standards protocols for host communications come as standard.

Advanced Process Control (APC) techniques like broadband optical monitoring with “real time in situ process reoptimisation” or “in situ” optical pyrometry tighten process repeatibilities and increase yields for the most demanding UV, VIS and IR optical stacks. Stress measurement during deposition enables tailoring of the process conditions for control of film stress in thick stacks or the avoidance of distortion in ultrathin optical components. Unicalc shaper optimisation solutions enable fast track development of efficient dielectric and metals deposition processes for optoelectronics and semiconductor applications, increase your throughputs and reduce your precious metals consumption costs.

“CUT YOUR MATERIALS COSTS AND IMPROVE PROCESS REPEATABILITIES”



THE BAK JUST THE RIGHT GEOMETRY

“THE MOST
FLEXIBLE
BAK SERIES
EVER BUILT”

The standard BAK chamber is just the starting point for a whole series of custom production solutions. Your BAK can also be delivered with “Lift Off” geometry where the source is lowered, and for the ultimate flexibility in deposition geometry we offer solutions for simple manual or motorized adaptation of geometry in the same chamber.

For handling of the most reactive coating materials or the very fastest cycle times, a “split chamber” variant enables the sources to be isolated in their own vacuum chamber and kept ready during main chamber vent, and for high uniformity “in-situ” dep & etch capability the chamber back can be extended to enable installation of movable ion sources.

Irrespective of the geometry, all our platform variants are engineered for rapid source access, replenishment and easy use with comfortable operator access for maintenance and repair.

“OUR ENGINEERING
TEAM HAS THE
SOLUTION”

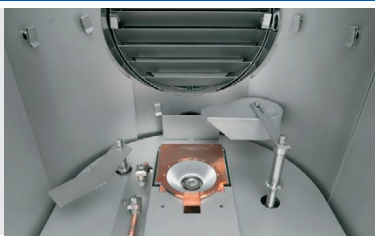
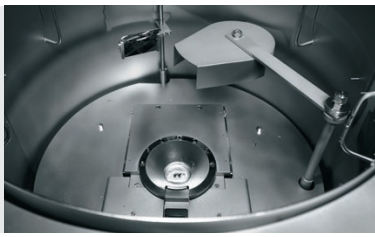
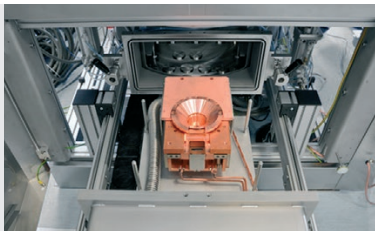
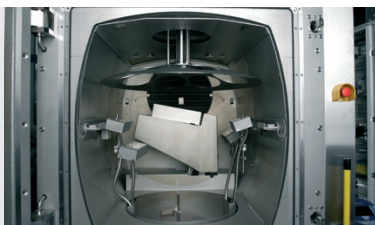
Platform geometry	Typical applications	
Standard throw	<ul style="list-style-type: none"> — High rate metallisation — Optical interference coatings — TCO deposition e.g. ITO 	
“Lift Off”	<ul style="list-style-type: none"> — Extended throw optimised for “Lift Off” processes — SAW/BAW/ Laser Bar devices 	
Split chamber	<ul style="list-style-type: none"> — “Reactive” coating materials — Special doping processes 	
Rear extension	<ul style="list-style-type: none"> — Combined dep and etch 	

BAK

A BLUEPRINT FOR SUCCESS

Process chamber

A tried and tested chamber design, extendable for different process geometries, flexible for different source configurations. Ready for whatever the future brings.

Sources

Choose from our biggest ever range of sources- from deposition to custom etch, e guns to effusion cells, barrel sources to boats. With closed loop process control to ensure the right thin film result every time.

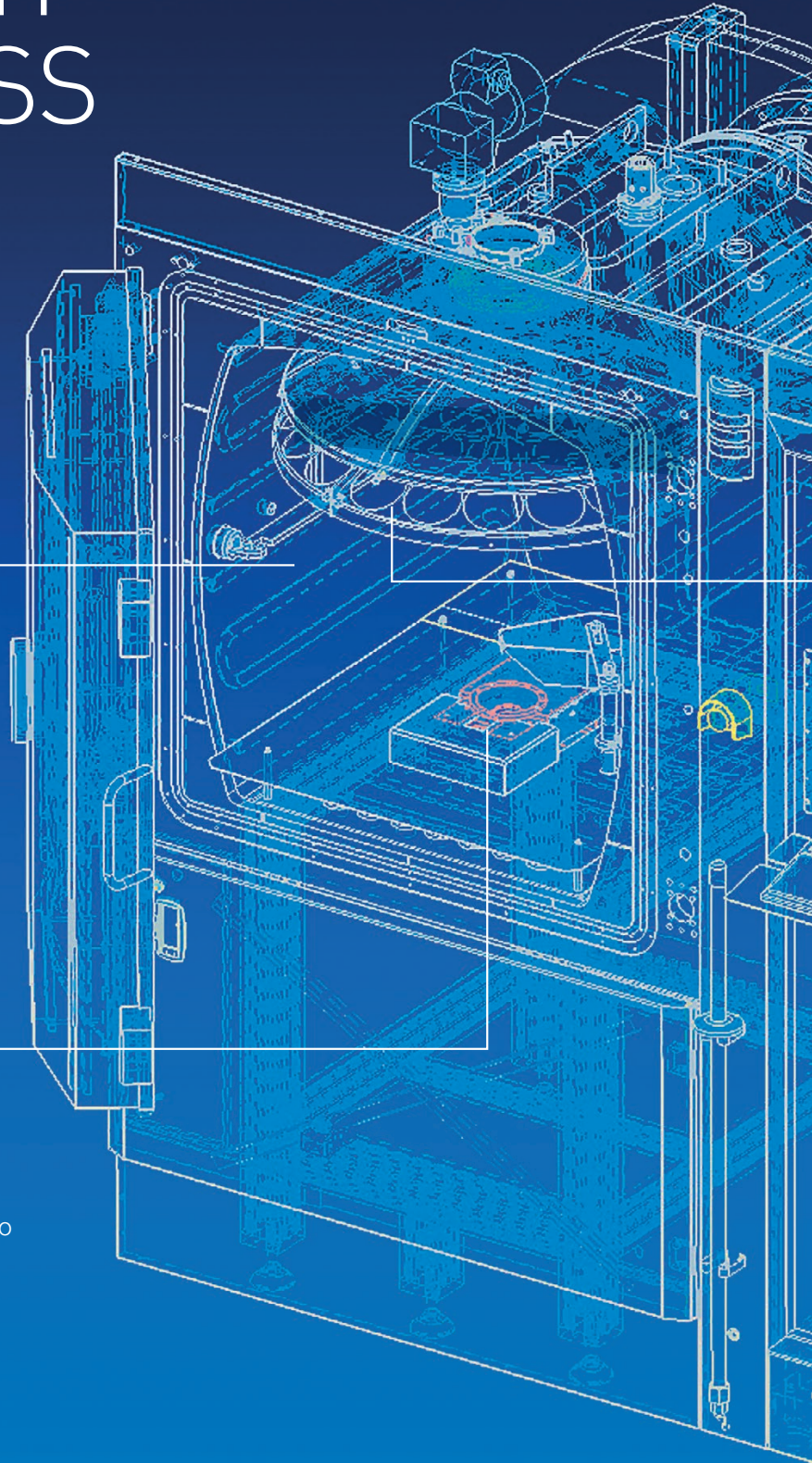

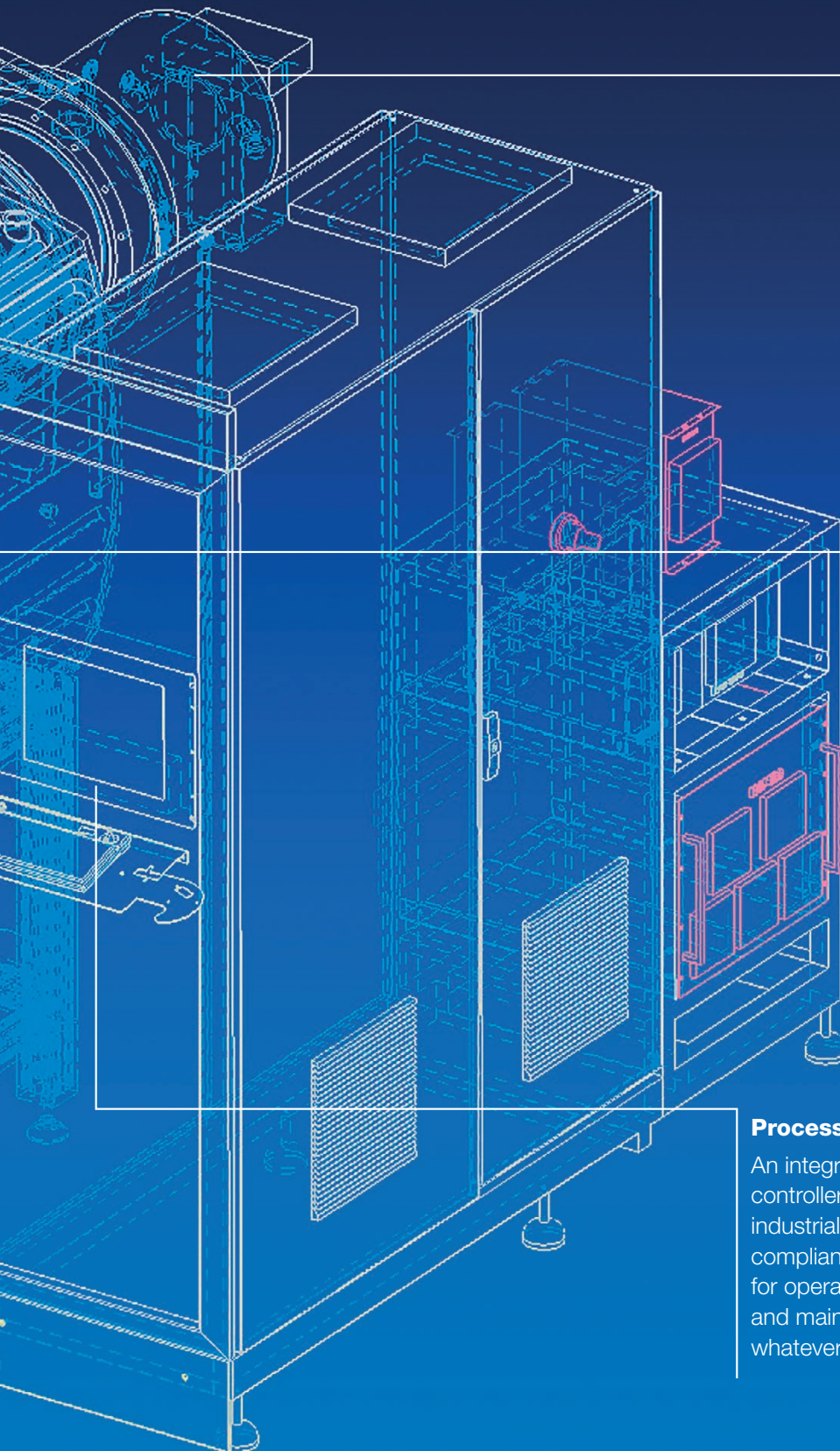

Pumping system

Pumping configurations according to your preference. Turbomolecular, diffusion or cryopumping. Tailor-made to bring you the best process results and highest production throughputs.

Custom tooling

Custom tooling for optics, optoelectronic and semiconductor processes. Manual handling or cassette to cassette with automated robot handling. With the BAK there is always a solution.

Process controller

An integrated system and process controller built around a robust industrial server, SEMATECH compliant, with intuitive handling for operators, process engineers and maintenance. Fully prepared for whatever sources you introduce.

THE BAK

SOURCES & LAYER THICKNESS CONTROL

“TIGHTER
PROCESS
TOLERANCES
THAN EVER”



QCM Crystal monitoring system for multi head control



Your BAK is prepared for installation of a whole range of deposition and etch sources including accessories like front and backside heating systems. The chamber base plate and side walls come with a series of standard feedthroughs enabling installation of the combinations of deposition and etch sources required for layer processing. All our sources are engineered for 24/7 production, robust and easy to maintain, optimised for the lowest materials utilisation and the best repeatability. As process requirements change in the future, simply reconfigure your system by moving, exchanging or adding new ones,

reconfigure your **“KHAN”** control system in just a few minutes and you are ready to go.

Control rates and terminate your layers with Evatec's QCM quartz monitoring technology at 5 or 6MHz featuring high sampling rates, high speed switch between crystals and simultaneous control of up to 4 quartz heads from a single controller. For real time direct measurement of optical layer performance during deposition choose monochromatic or broadband optical monitoring techniques for UV, VIS and IR.

Maximise your process performance by choosing from our widest ever range of sources. From simple thermal boats and high capacity barrel sources to effusion cells, E Guns and etch sources.

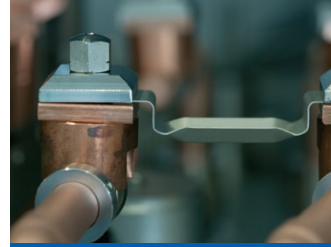

Thermal Evaporation

Standard and custom designs for complex substrate geometries and a large variety of coating materials



E Guns

From 1 to 60 pocket, single or co-evap, for dielectrics, metals and TCOs

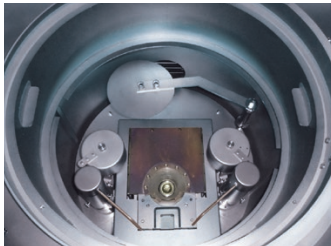

Wire Feeder

Two position wire feeder for source replenishment in thick layer deposition



Barrel Source

A range of source volumes for deposition of very thick layers



Effusion Cells

Complex alloying processes and processing of very low vapour pressure materials at up to 2000°C

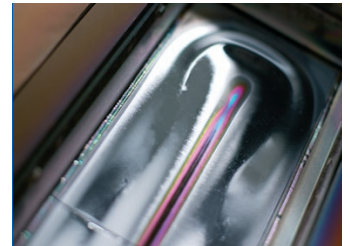

Sputter

Metals, dielectrics and TCOs. Closed loop reactive processes. Co-sputter for complex materials



PIAD

Improved film qualities, lower process temperatures and shorter process times



Etch

Round and moveable linear mills for high rate, accurate in situ dep and etch processes

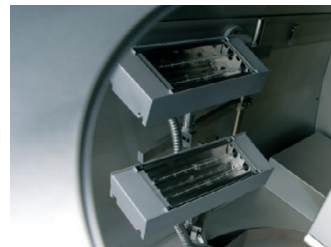

Heating

Combined front and /or backside heating for process temperatures up to 350°C

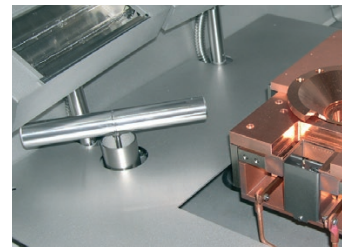

Glow Discharge

700W or 2000W according to application

From multilayer optical stacks with edge tolerances <1nm to ultrathin 1nm precious metal layers and co-evaporation of alloys there is a BAK process control solution that fits.

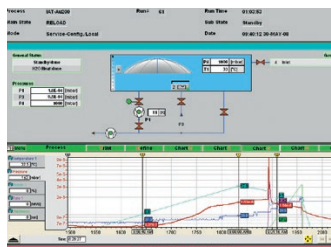

KHAN

KHAN process controller. Closed loop control with user defined parameter tracking and full run statistics logging



Quartz Monitoring

Single, 6, or 12 way quartz with increased sampling rates for termination accuracy in single and co deposition processes



Optical Monitoring

UV to IR, monochromatic or broadband, test glasses or direct substrate measurement

TOOLING THAT MAKES THE DIFFERENCE





Knudsen planetary



Flip system for double-sided coating

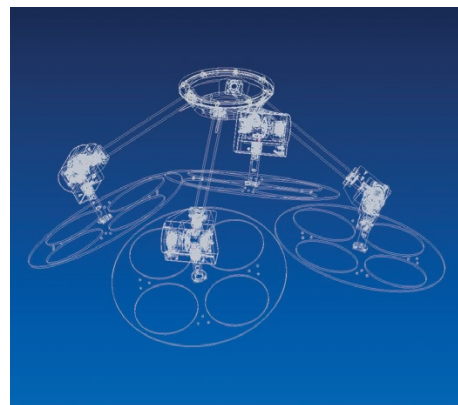

Custom substrate movement

Example of optimised capacity based on tooling choice for BAK 761

Substrate Size	Substrate Handling		
	4 segments	3 segments	Knudsen
3"	64	72	123
4"	40	39	78
6"	16	18	33
8"	8	9	15

Evatec’s portfolio of tooling solutions is designed to maximise batch capacity for evaporation processes without compromise on film quality. Choose from single piece and segmented domes with standard or “lift off” geometries or flip systems for double sided processes. For high rate metallisation our range of planetary system designs enables larger batch sizes and lowest materials utilisation and for complex substrate geometries our engineering department offers a bespoke design service.

Where wall or door mounted large area rectangular sputter sources are specified, we offer proven rotary cage tooling designs for easy load / unload of carriers and maximum coating area per batch.

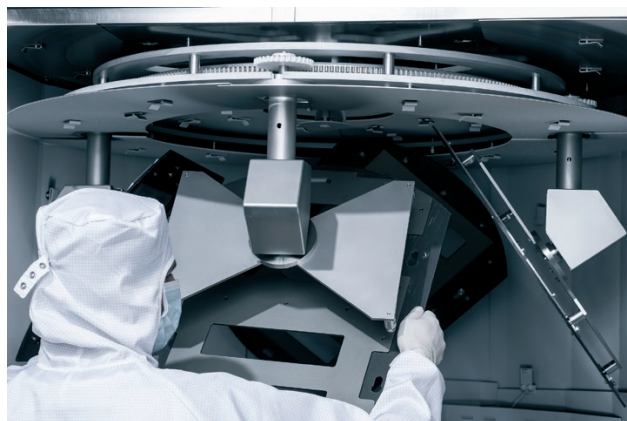

Custom planetary tooling in BAK 1401

THE BAK CUSTOMISED JUST FOR YOU

“BUILT FOR
THE LONGEST
LIFETIME IN
THE INDUSTRY”



Evatec's custom engineering capabilities add further possibilities to ensure seamless integration of the BAK in your production line. Here are just a few of the engineering options available:

- Add our 'AUTOLOAD' cassette to cassette handling solutions with integrated robot load / unload of the calotte to eliminate all manual handling and enable automated individual wafer tracking
- Integrate additional processing chambers along side your BAK for pre or post deposition processes in controlled environments
- Incorporate vacuum load lock systems for custom applications and increased throughput

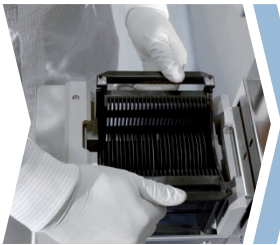

1. Front end cassette load and unload. Wafer sizes up to 8 inch.



2. Precise handling of wafer by robot, including wafer centering.

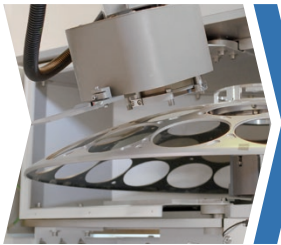

3. Dome loading including metrology wafers

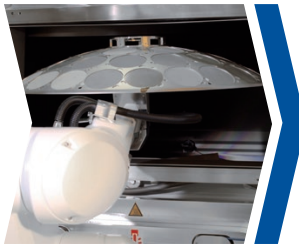

4. Dome transfer through dedicated side port either direct to coater or via loadlock chamber.

Whichever BAK you choose, the Evatec team is committed to deliver BAK production tools for Semiconductor, Precision Optics, and Optoelectronics that stand out for their reliability, leading process performance, and long lifetime. To find out more simply call your local sales and service team or contact us at www.evatecnet.com



ABOUT EVATEC

Evatec AG

Hauptstrasse 1a
CH-9477 Trübbach
Switzerland
Tel: + 41 81 403 80 00
Fax: + 41 81 403 80 01
info@evatecnet.com
www.evatecnet.com

Evatec offers complete solutions for thin film deposition and etch in the Advanced Packaging, Power Devices, MEMS, Wireless Communication, Optoelectronics and Photonics markets.

Evatec engineers are able to offer practical production advice from R&D to prototyping and mass production. We recognize that no single technique offers the answer to all problems.

With a technology portfolio including standard and enhanced evaporation, a range of advanced sputter technologies as well as plasma deposition & etch, we are ready to offer sampling services and custom engineering to meet our customers individual needs.

We provide sales and service through our global network of local offices.

For more information visit us at www.evatecnet.com or contact our head office.

Product descriptions, photos and data are supplied within the brochure for general information only and may be superseded by any data contained within Evatec quotations, manuals or specifications.

Edition 4: Reprinted February 2019, first printed August 2017. (1st edition printed Dec 2012. 2nd edition printed May 2014. 3rd edition printed May 2016).